

ATV340U55N4

variable speed drive - 5.5kW- 400V - 3 phases -
ATV340

Product availability : Stock - Normally stocked in distribution facility



Price* : 1,006.20 USD



Main

| | |
|------------------------------|--|
| Range of product | Altivar Machine ATV340 |
| Product or component type | Variable speed drive |
| Product specific application | Machine |
| Variant | Standard version |
| Mounting mode | Cabinet mount |
| Communication port protocol | Modbus serial |
| Option card | communication module, Profibus DP V1 communication module, Profinet communication module, DeviceNet communication module, CANopen communication module, EtherCAT |
| Phase | 3 phase |
| Supply frequency | 50...60 Hz +/- 5 % |
| [Us] rated supply voltage | 380...480 V - 15...10 % |
| Nominal output current | 12.7 A |
| Motor power kW | 7.5 kW normal duty 5.5 kW heavy duty |
| Maximum Horse Power Rating | 10 hp normal duty 7 hp heavy duty |
| EMC filter | Class C3 EMC filter integrated |
| IP degree of protection | IP20 |

Complementary

| | |
|-----------------------|---|
| Discrete input number | 5 |
| Discrete input type | PTI programmable as pulse input 0...30 kHz, 24 V DC 30 V) DI1...DI5 safe torque off, 24 V DC 30 V)3.5 kOhm programmable |

* Price is "List Price" and may be subject to a trade discount – check with your local distributor or retailer for actual price.

| | |
|-------------------------------------|--|
| Number of preset speeds | 16 preset speeds |
| Discrete output number | 2.0 |
| Discrete output type | Programmable output DQ1, DQ2 30 V DC 100 mA |
| Analogue input number | 2 |
| Analogue input type | A11 software-configurable current 0...20 mA 250 Ohm 12 bits A11 software-configurable temperature probe or water level sensor A11 software-configurable voltage 0...10 V DC 31.5 kOhm 12 bits A12 software-configurable voltage - 10...10 V DC 31.5 kOhm 12 bits |
| Analogue output number | 2 |
| Analogue output type | Software-configurable voltage AQ1 0...10 V DC 470 Ohm 10 bits Software-configurable current AQ1 0...20 mA 500 Ohm 10 bits |
| Relay output number | 2 |
| Output voltage | <= power supply voltage |
| Relay output type | Relay outputs R1A Relay outputs R1C 100000 cycles Relay outputs R2A Relay outputs R2C 100000 cycles |
| Maximum switching current | Relay output R1C resistive, cos phi = 1 3 A 250 V AC Relay output R1C resistive, cos phi = 1 3 A 30 V DC Relay output R1C inductive, cos phi = 0.4 7 ms 2 A 250 V AC Relay output R1C inductive, cos phi = 0.4 7 ms 2 A 30 V DC Relay output R2C resistive, cos phi = 1 5 A 250 V AC Relay output R2C resistive, cos phi = 1 5 A 30 V DC Relay output R2C inductive, cos phi = 0.4 7 ms 2 A 250 V AC Relay output R2C inductive, cos phi = 0.4 7 ms 2 A 30 V DC |
| Minimum switching current | Relay output R1B 5 mA 24 V DC Relay output R2C 5 mA 24 V DC |
| Physical interface | 2-wire RS 485 |
| Connector type | 1 RJ45 |
| Method of access | Slave Modbus RTU |
| Transmission rate | 4.8 kbit/s 9.6 kbit/s 19.2 kbit/s 38.4 kbit/s |
| Transmission frame | RTU |
| Number of addresses | 1...247 |
| Data format | 8 bits, configurable odd, even or no parity |
| Type of polarization | No impedance |
| 4 quadrant operation possible | True |
| Asynchronous motor control profile | Variable torque standard Optimized torque mode Constant torque standard |
| Synchronous motor control profile | Permanent magnet motor Reluctance motor |
| Pollution degree | 2 EN/IEC 61800-5-1 |
| Maximum output frequency | 0.599 kHz |
| Acceleration and deceleration ramps | Linear adjustable separately from 0.01...9999 s S, U or customized |
| Motor slip compensation | Adjustable Automatic whatever the load Can be suppressed Not available in permanent magnet motor law |
| Switching frequency | 2...16 kHz adjustable 7...16 kHz with derating factor |
| Nominal switching frequency | 4 kHz |
| Braking to standstill | By DC injection |
| Brake chopper integrated | True |
| Line current | 15.3 A 380 V normal duty) 12.2 A 480 V normal duty) 20.0 A 380 V heavy duty) 16.0 A 480 V heavy duty) |
| Line current | 20 A 380 V without line choke heavy duty) |

| | |
|--|--|
| | 16 A 480 V without line choke heavy duty) 15.3 A 380 V with external line choke normal duty) 12.2 A 480 V with external line choke normal duty) 11.6 A 380 V with external line choke heavy duty) 9.4 A 480 V with external line choke heavy duty) |
| Maximum Input Current per phase | 20.0 A |
| Maximum output voltage | 480 V |
| Apparent power | 12.1 kVA 480 V normal duty) 13.3 kVA 480 V heavy duty) |
| Maximum transient current | 18.2 A 60 s normal duty) 19.1 A 60 s heavy duty) 22.3 A 2 s normal duty) 22.9 A 2 s heavy duty) |
| Electrical connection | Screw terminal 4...6 mm ² DC bus Screw terminal 0.2...2.5 mm ² control Screw terminal 1.5...6 mm ² line side Screw terminal 1.5...6 mm ² motor |
| Prospective line I _{sc} | 22 kA |
| Base load current at high overload | 12.7 A |
| Base load current at low overload | 16.5 A |
| Power dissipation in W | Natural convection 134 W 380 V 4 kHz heavy duty) Forced convection 134 W 380 V 4 kHz heavy duty) Natural convection 164 W 380 V 4 kHz normal duty) Forced convection 164 W 380 V 4 kHz normal duty) |
| Electrical connection | DC bus screw terminal 4...6 mm ² AWG 12...AWG 10 Control screw terminal 0.2...2.5 mm ² AWG 24...AWG 12 Line side screw terminal 1.5...6 mm ² AWG 14...AWG 10 Motor screw terminal 1.5...6 mm ² AWG 14...AWG 10 |
| With safety function Safely Limited Speed (SLS) | True |
| With safety function Safe brake management (SBC/SBT) | True |
| With safety function Safe Operating Stop (SOS) | False |
| With safety function Safe Position (SP) | False |
| With safety function Safe programmable logic | False |
| With safety function Safe Speed Monitor (SSM) | False |
| With safety function Safe Stop 1 (SS1) | True |
| With sft fct Safe Stop 2 (SS2) | False |
| With safety function Safe torque off (STO) | True |
| With safety function Safely Limited Position (SLP) | False |
| With safety function Safe Direction (SDI) | False |
| Protection type | Thermal protection motor Safe torque off: motor Motor phase loss motor Thermal protection drive Safe torque off: drive Overheating: drive Overcurrent drive Output overcurrent between motor phase and earth drive Output overcurrent between motor phases drive Short-circuit between motor phase and earth drive Short-circuit between motor phases drive Motor phase loss drive DC Bus overvoltage drive Line supply overvoltage drive Line supply undervoltage drive Input supply loss drive Exceeding limit speed drive Break on the control circuit drive |
| Width | 4.33 in (110.0 mm) |

| | |
|---------------------------|---|
| Height | 10.63 in (270.0 mm) |
| Depth | 9.21 in (234.0 mm) |
| Net Weight | 6.39 lb(US) (2.9 kg) |
| Continuous output current | 16.5 A at 4 kHz for normal duty 12.7 A at 4 kHz for heavy duty |

Environment

| | |
|--|--|
| Operating altitude | <= 9842.52 ft (3000 m) with current derating above 1000m |
| Operating position | Vertical +/- 10 degree |
| Product certifications | UL CSA TÜV EAC CTick RoHS |
| Marking | CE |
| Standards | EN/IEC 61800-3 EN/IEC 61800-5-1 IEC 60721-3 IEC 61508 IEC 13849-1 UL 618000-5-1 UL 508C |
| Assembly style | With heat sink |
| Electromagnetic compatibility | Electrostatic discharge immunity test level 3 IEC 61000-4-2 Radiated radio-frequency electromagnetic field immunity test level 3 IEC 61000-4-3 Electrical fast transient/burst immunity test level 4 IEC 61000-4-4 1.2/50 µs - 8/20 µs surge immunity test level 3 IEC 61000-4-5 Conducted radio-frequency immunity test level 3 IEC 61000-4-6 |
| Environmental class (during operation) | Class 3C3 according to IEC 60721-3-3 Class 3S3 according to IEC 60721-3-3 |
| Maximum acceleration under shock impact (during operation) | 70 m/s ² at 22 ms |
| Maximum acceleration under vibrational stress (during operation) | 5 m/s ² at 9...200 Hz |
| Maximum deflection under vibratory load (during operation) | 1.5 mm at 2...9 Hz |
| Permitted relative humidity (during operation) | Class 3K5 according to EN 60721-3 |
| Volume of cooling air | 20077.44 Gal/hr(US) (76.0 m3/h) |
| Type of cooling | Forced convection |
| Overvoltage category | Class III |
| Regulation loop | Adjustable PID regulator |
| Noise level | 46.6 dB |
| Pollution degree | 2 |
| Ambient air transport temperature | -40...158 °F (-40...70 °C) |
| Ambient air temperature for operation | 5...122 °F (-15...50 °C) without derating vertical position) 122...140 °F (50...60 °C) with derating factor vertical position) |
| Ambient air temperature for storage | -40...158 °F (-40...70 °C) |
| Isolation | Between power and control terminals |

Ordering and shipping details

| | |
|-----------------------|-------------------------------|
| Category | 22182 - ATV340 (1 THRU 25 HP) |
| Discount Schedule | CP4B |
| GTIN | 00785901657620 |
| Nbr. of units in pkg. | 1 |
| Package weight(Lbs) | 8.24 lb(US) (3.74 kg) |
| Returnability | Yes |
| Country of origin | ID |

Packing Units

| | |
|------------------------------|-------------------------|
| Unit Type of Package 1 | PCE |
| Package 1 Height | 5.12 in (13 cm) |
| Package 1 width | 14.57 in (37 cm) |
| Package 1 Length | 12.40 in (31.5 cm) |
| Unit Type of Package 2 | S04 |
| Number of Units in Package 2 | 2 |
| Package 2 Weight | 17.95 lb(US) (8.14 kg) |
| Package 2 Height | 11.81 in (30 cm) |
| Package 2 width | 15.75 in (40 cm) |
| Package 2 Length | 23.62 in (60 cm) |
| Unit Type of Package 3 | P06 |
| Number of Units in Package 3 | 10 |
| Package 3 Weight | 110.67 lb(US) (50.2 kg) |
| Package 3 Height | 31.50 in (80 cm) |
| Package 3 width | 31.50 in (80 cm) |
| Package 3 Length | 23.62 in (60 cm) |

Offer Sustainability

| | |
|----------------------------|---|
| Sustainable offer status | Green Premium product |
| California proposition 65 | WARNING: This product can expose you to chemicals including: Lead and lead compounds, which is known to the State of California to cause cancer and birth defects or other reproductive harm. For more information go to www.P65Warnings.ca.gov |
| REACH Regulation | REACH Declaration |
| EU RoHS Directive | Pro-active compliance (Product out of EU RoHS legal scope) EU RoHS Declaration |
| Mercury free | Yes |
| RoHS exemption information | Yes |
| China RoHS Regulation | China RoHS declaration |
| Environmental Disclosure | Product Environmental Profile |
| Circularity Profile | End of Life Information |
| WEEE | The product must be disposed on European Union markets following specific waste collection and never end up in rubbish bins. |
| Upgradeability | Upgraded components available  |

Dimensions

Views: Front - Left - Rear

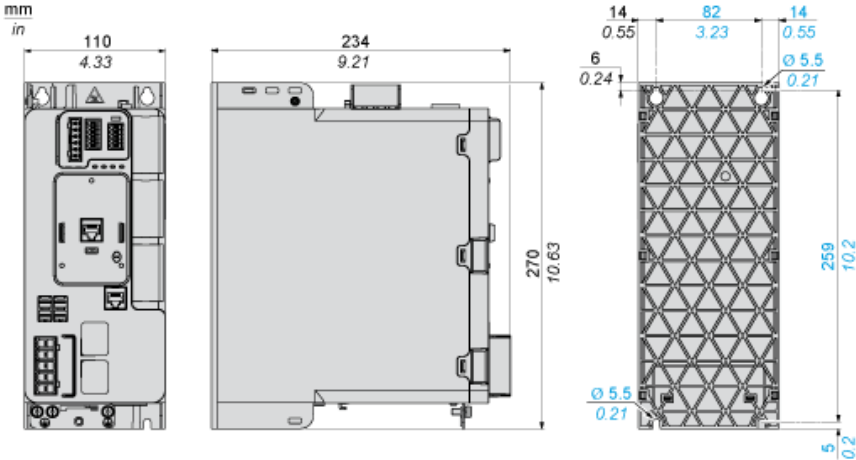

Clearance

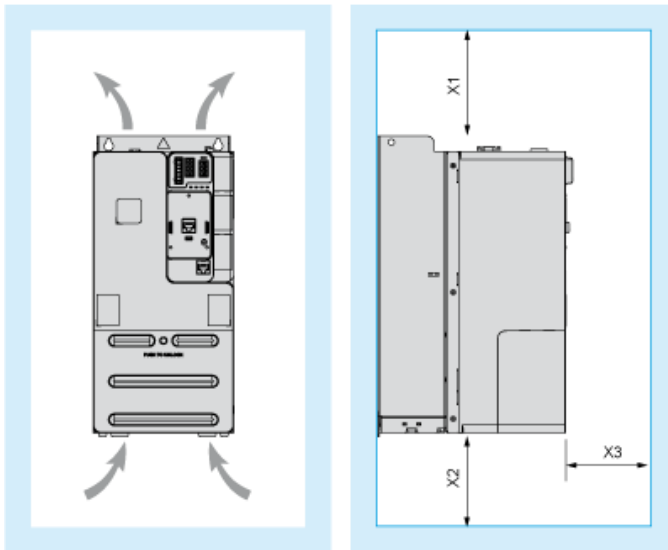

Dimensions in mm

| X1 | X2 | X3 |
|-------|-------|------|
| ≥ 100 | ≥ 100 | ≥ 60 |

Dimensions in in.

| X1 | X2 | X3 |
|--------|--------|--------|
| ≥ 3.94 | ≥ 3.94 | ≥ 2.36 |

Mounting Types

Mounting Type A: Side by Side IP20

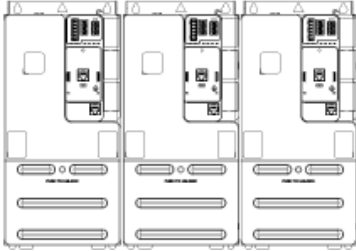

Possible, at ambient temperature $\leq 50\text{ }^{\circ}\text{C}$ (122 $^{\circ}\text{F}$)

Mounting Type B: Individual IP20

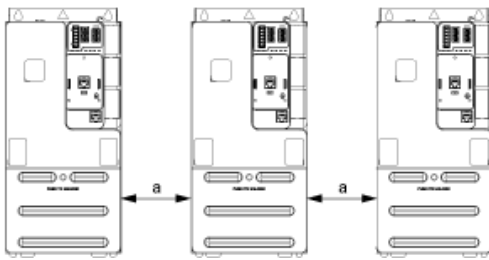

$a \geq 50\text{ mm}$ (1.97 in.) from 50...60 $^{\circ}\text{C}$, no restriction below 50 $^{\circ}\text{C}$

Connections and Schema

Three-phase Power Supply with Upstream Breaking via Line Contactor Without Safety Function STO

Connection diagrams conforming to standards ISO13849 category 1 and IEC/EN 61508 capacity SIL1, stopping category 0 in accordance with standard IEC/EN 60204-1.

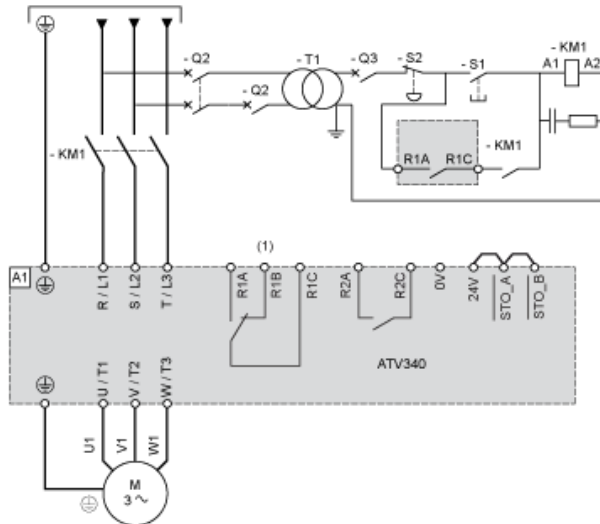

- (1) Use relay output R1 set to operating state Fault to switch Off the product once an error is detected.
A1 : Drive
KM1 : Line Contactor
Q2, Q3 : Circuit breakers
S1 : Pushbutton
S2 : Emergency stop
T1 : Transformer for control part

Three-phase Power Supply With Downstream Breaking via Switch Disconnecter

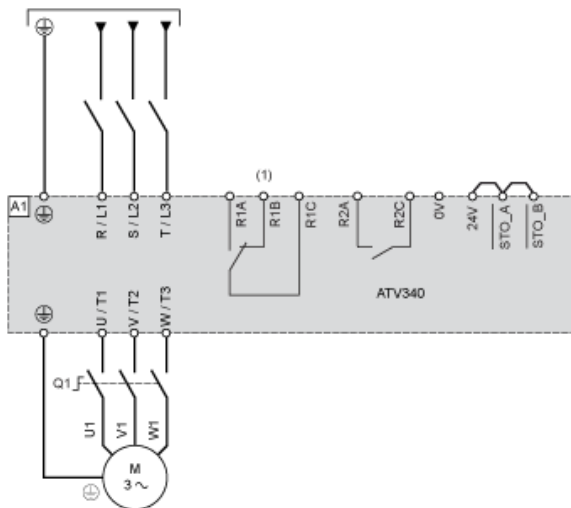

- (1) Use relay output R1 set to operating state Fault to switch Off the product once an error is detected.
A1 : Drive
Q1 : Switch disconnector

Sensor Connection

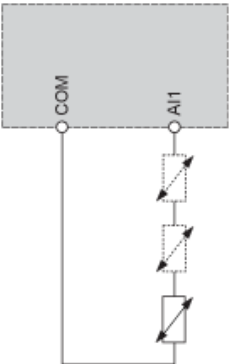

It is possible to connect either 1 or 3 sensors on terminals AI1.

Control Block Wiring Diagram

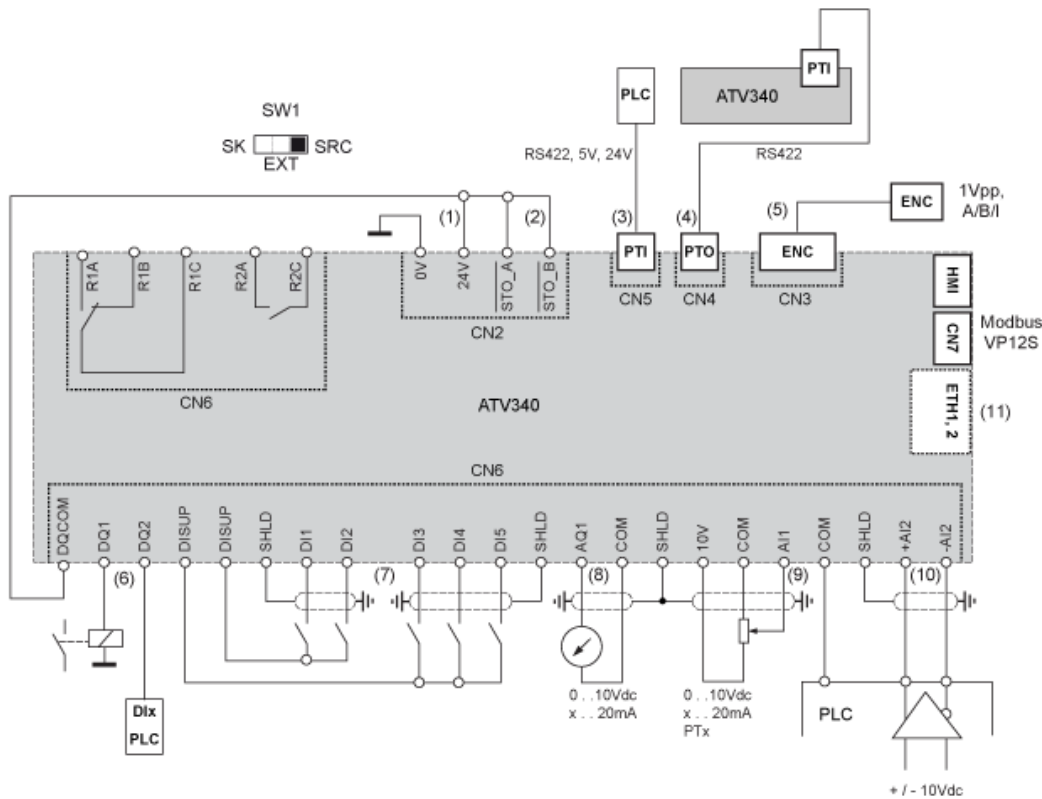

- (1) 24V supply (STO)
 - (2) STO - Safe Torque Off
 - (3) PTI - Pulse Train In
 - (4) PTO - Pulse Train Out
 - (5) Motor Encoder connection
 - (6) Digital outputs
 - (7) Digital inputs
 - (8) Analog output
 - (9) Analog input
 - (10) Differential Analog Input
 - (11) Ethernet port (only on Ethernet drive version)
- SW1 : Sink/Source switch
 R1A, R1B, R1C Relay
 R2A, R2C Sequence relay

Digital Inputs Wiring

Digital Inputs: Internal Supply

Using DISUP Signal

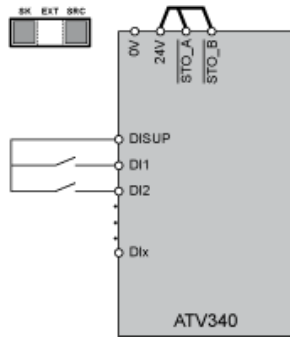

In SRC position DISUP outputs 24 V. In SK position DISUP is connected to 0 V.

Digital Inputs: External Supply

Positive Logic, Source, European Style

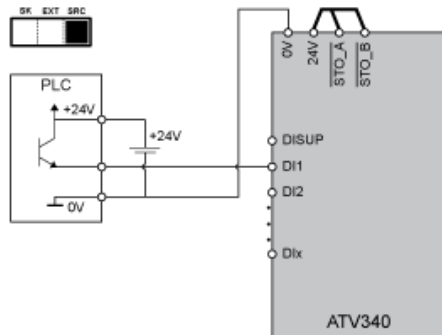

Negative Logic, Sink, Asian Style

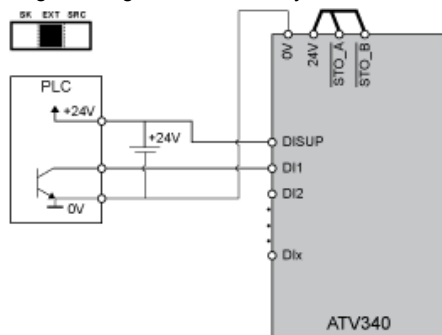

Digital Inputs: Internal supply

Negative Logic, Sink, Asian Style

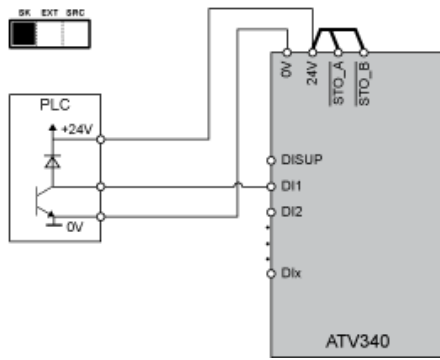

Digital Outputs Wiring

Digital Outputs: Internal Supply

Positive Logic, Source, European Style, DQCOM to +24V

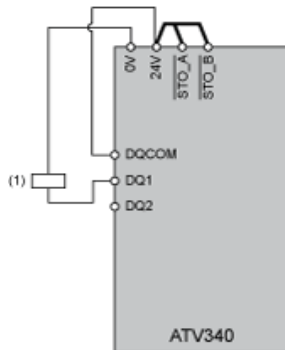

(1) Relay or valve

Negative Logic, Sink, Asian Style, DQCOM to 0V

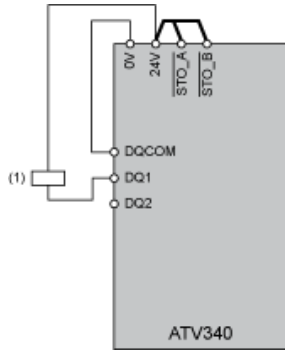

(1) Relay or valve

Digital Outputs: External Supply

Positive Logic, Source, European Style, DQCOM to +24V

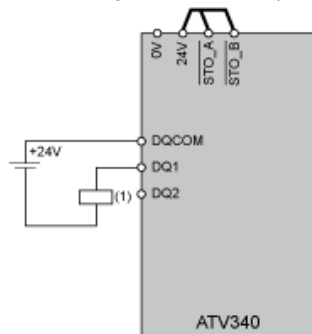

(1) Relay or valve

Negative Logic, Sink, Asian Style, DQCOM to 0V

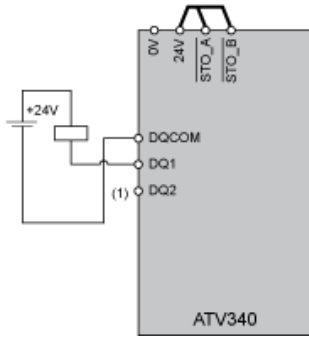

(1) Relay or valve

Open Loop Applications

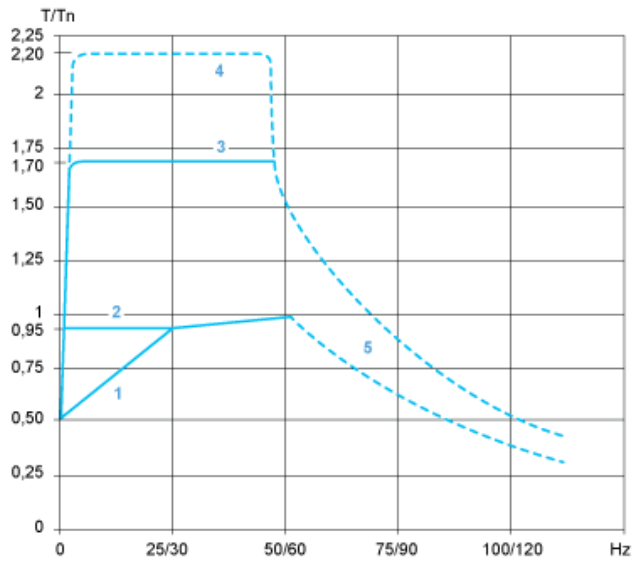

- 1 : Self-cooled motor: continuous useful torque
- 2 : Force-cooled motor: continuous useful torque
- 3 : Overtorque for 60 s maximum
- 4 : Transient overtorque for 2 s maximum
- 5 : Torque in overspeed at constant power

Closed Loop Applications

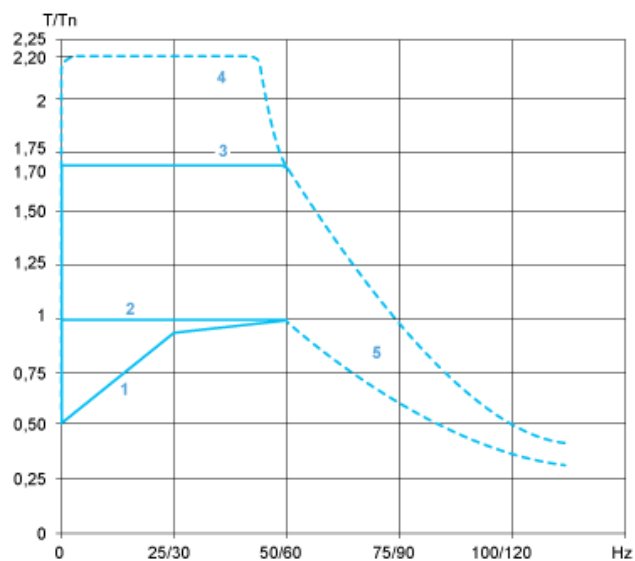

- 1 : Self-cooled motor: continuous useful torque
- 2 : Force-cooled motor: continuous useful torque
- 3 : Overtorque for 60 s maximum
- 4 : Transient overtorque for 2 s maximum
- 5 : Torque in overspeed at constant power